

# User Guide

Sona<sup>™</sup> IF573 Development Kit

Part # 453-00119-K1, 453-00120-K1

*Version 1.0*

---

## REVISION HISTORY

Version	Date	Notes	Contributor(s)	Approver
1.0	23 Oct 2023	Initial Release	Alexander Mohr	Andy Ross

## TABLE OF CONTENTS

1	Overview .....	4
2	Sona™ IF573 Development Kit Part Numbers .....	4
3	Sona™ IF573 Development Platform .....	5
3.1	Key Features .....	5
4	Development Kit Contents .....	6
5	Sona™ IF573 Development Boards .....	9
5.1	Sona™ IF573 Series M.2 Variant Development Board .....	9
5.2	Sona™ IF573 Development Board Schematics .....	11
5.2.1	Sona™ IF573 Development Board - Block Diagram .....	11
5.2.2	Sona™ IF573 Development Board - Power Schematic .....	12
5.2.3	Sona™ IF573 Development Board - Peripheral Schematic .....	13
5.2.4	Sona™ IF573 Development Board Connector Schematic .....	14
6	Sona™ IF573 Daughter Boards .....	15
6.1	Sona™ IF573 M.2 Daughter Board .....	15
6.1.1	Sona™ IF573 M.2 Daughter Board Schematic .....	15
6.2	Sona™ IF573 Mini PCIe Daughter Board .....	16
6.2.1	Sona™ IF573 mini PCIe Daughter Board Schematic .....	16
6.3	Sona™ IF573 SD Daughter Board .....	17
6.3.1	Sona™ IF573 SD Daughter Board Schematic .....	17
6.4	Sona™ IF573 Micro SD Daughter Board .....	18
7	Sona™ IF573 Development Kit Antennas .....	19
7.1	WLAN Tri-Band 2.4/5/6 GHz Antenna .....	19
7.2	Bluetooth™ 2.4 (and 5 and 6) GHz Antenna .....	19
8	Sona™ IF573 Development Board High Speed Cable and Connectors .....	20
8.1	Sona™ IF573 High Speed Cable Connector Instructions .....	21
9	Additional Information .....	25

## 1 OVERVIEW

The Laird Connectivity Sona™ IF573 development kit provides a platform for rapid developing and testing all variations of the Sona™ IF573 modules. This document describes the development board hardware, highlighting the setup and interfaces available to maximize user flexibility in developing these applications.

Because the Laird Connectivity Sona™ IF573 DVK not only serves as a development kit for customers for the M.2 based Sona™ IF573 modules but also is used internally by Laird it offers a few features that are not available for development with the M.2 cards. Those features are marked “**for internal use only**” and need to be set according to the instructions in this guide.

---

**Note:** This DVK is not to be used as a reference design, please follow the data sheet and M.2 specification.

---

## 2 SONA™ IF573 DEVELOPMENT KIT PART NUMBERS

**Table 1: Available Development Kits**

Part Number	Product Description
453-00119-K1	Development Kit, Sona™ IF573 Series, M.2, Key E Connector with SDIO and UART Interfaces
453-00120-K1	Development Kit, Sona™ IF573 Series, M.2, Key E Connector with PCIe and UART Interfaces

**Table 2: Applicable Sona™ IF573 Module Part Numbers**

Part Number	Product Description
453-00117	Sona™ IF573 1318 Module, MHF4 Antenna connectors
453-00118	Sona™ IF573 1318 Module, RF Trace Pin
453-00119	Sona™ IF573 M.2 Key E, SDIO, UART Interface Module
453-00120	Sona™ IF573 M.2 Key E, PCIe, UART Interface Module

## 3 SONA™ IF573 DEVELOPMENT PLATFORM

The Sona™ IF573 development platform is a development tool that highlights the capabilities of the Sona™ IF573 Module. It was designed to provide various communication software and hardware interfaces to a Linux host. The development platform is supplied with necessary cabling, antennas, power supplies and adapter/daughter boards for multiple interface options. The development kit is supplied with high-speed cabling and adapter/daughter boards to provide UART as well as high-speed SDIO and PCIe data interfaces to an external Linux host.

On-board headers and jumpers provide a convenient method of isolating power and signal nets for debugging and power measurements during hardware and software development.

### 3.1 Key Features

The Sona™ IF573 Series M.2, Key E, SDIO, UART Development Kit has the following features:

- Standard PCIe M.2 Key E Connector.
- SDIO/UART M.2 Module included in the kit
- The Bluetooth™ UART interface is selectable between the on-board FTDI USB to UART IC or external UART via jumpers.
- On-board 3.3V DC regulator provides main Module power.
- Main module power can be isolated and provided externally for power requirement measurements.
- All module I/O's and Bluetooth™ UART are brought to headers for easy debugging of control signals and GPIO.
- High speed cable and connectors provide multiple communication interfaces to host platform using a common development board.
- Wi-Fi and Bluetooth™ antennas included with each kit.

The Sona™ IF573 Series M.2, Key E, PCIe, UART Development Kit has the following features:

- Standard PCIe M.2 Key E Connector.
- PCIe/UART M.2 Module included in the kit
- The Bluetooth™ UART interface is selectable between the on-board FTDI USB to UART IC or external UART via jumpers.
- On-board 3.3V DC regulator provides main Module power.
- Main module power can be isolated and provided externally for power requirement measurements.
- All module I/O's and Bluetooth™ UART are brought to headers for easy debugging of control signals and GPIO.
- High speed cable and connectors provide multiple communication interfaces to host platform using a common development board.
- Wi-Fi and Bluetooth™ antennas included with each kit.

## 4 DEVELOPMENT KIT CONTENTS

Table 3 - 453-00119-K1 Development Kit, Sona™ IF573 Series, M.2, Key E, SDIO, UART

<b>Development Board</b>	Sona™ IF573 Series M.2 Dev Board
<b>M.2 Module</b>	453-00119 SDIO/UART M.2 Module
<b>Power Supply</b>	Wide input-range AC Adapter, 12V-1A, US, EU, AU, UK w/ Barrel Connector
<b>Antennas</b>	<ul style="list-style-type: none"> <li>▪ 1pc FlexMIMO 6E EFD2471A3S-10MH4L, PIFA Antenna with MHF4L Connector</li> <li>▪ 1pc FlexPIFA 6E EFB2471A3S-10MH4L, PIFA Antenna with MHF4L Connector</li> </ul>
<b>Cables</b>	<ul style="list-style-type: none"> <li>▪ Micro USB, 1.2m, 28awg, Black</li> <li>▪ I-PEX High Speed Data, CABLINE VSII 40P Harness 1-N AWG40 Blue, 100mm</li> </ul>
<b>Adapter Boards</b>	<ul style="list-style-type: none"> <li>▪ M.2, Key E, Daughter Board</li> <li>▪ SDIO Daughter Board</li> <li>▪ Micro SDIO Daughter Board</li> </ul>

**Note: The DVK contains no software. For the required software please visit the [Sona IF573 product page](#) on the Laird Connectivity website.**

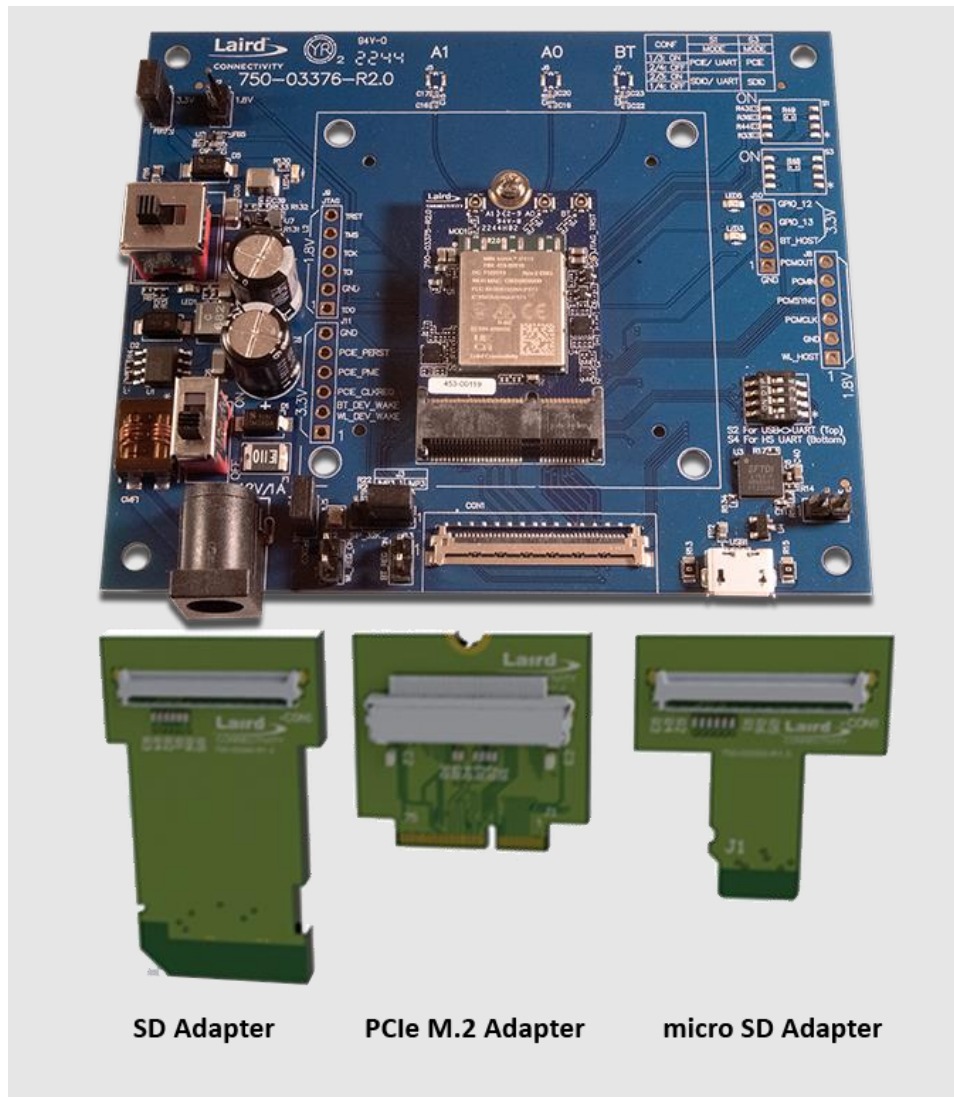

Figure 1: 453-00119-K1 Development Kit, Sona™ IF573 Series, M.2, Key E, SDIO, UART

Table 4 - 453-00120-K1 Development Kit, Sona™ IF573 Series, M.2, Key E, PCIe, UART

<b>Development Board</b>	Sona™ IF573 Series M.2 Dev Board
<b>M.2 Module</b>	453-00120 PCIe/UART M.2 Module
<b>Power Supply</b>	Wide input-range AC Adapter, 12V-1A, US, EU, AU, UK w/ Barrel Connector
<b>Antennas</b>	<ul style="list-style-type: none"> <li>1pc FlexMIMO 6E EFD2471A3S-10MH4L, PIFA Antenna with MHF4L Connector</li> <li>1pc FlexPIFA 6E EFB2471A3S-10MH4L, PIFA Antenna with MHF4L Connector</li> </ul>
<b>Cables</b>	<ul style="list-style-type: none"> <li>Micro USB, 1.2m, 28awg, Black</li> <li>I-PEX High Speed Data, CABLINE VSII 40P Harness 1-N AWG40 Blue, 100mm</li> </ul>
<b>Adapter Boards</b>	<ul style="list-style-type: none"> <li>M.2, Key E, Daughter Board</li> <li>mini PCIe Daughter Board</li> </ul>

Note: The DVK contains no software. For the required software please visit the [Sona IF573 product page](#) on the Laird Connectivity website.

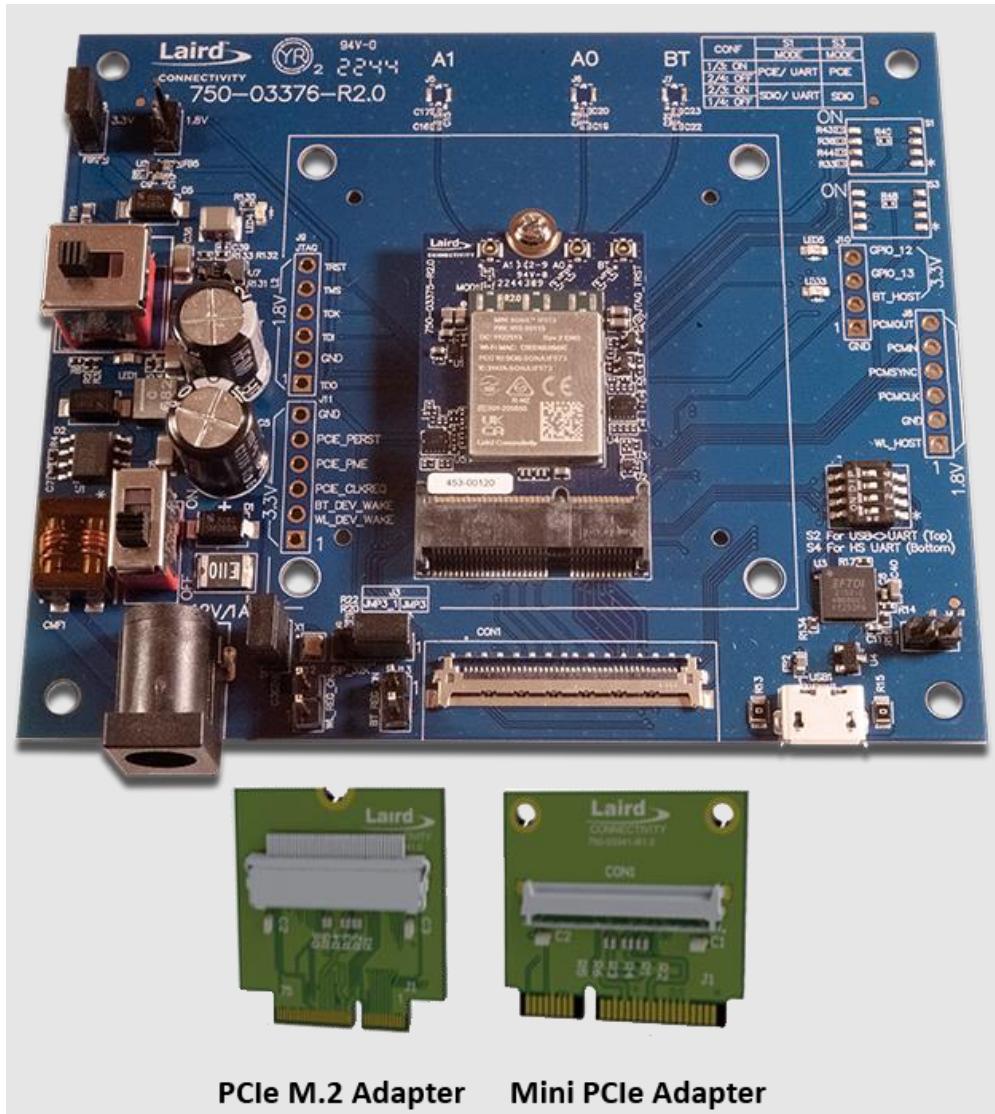

Figure 2: 453-00120-K1 Development Kit, Sona™ IF573 Series, M.2, Key E, PCI-e, UART



## 5 SONA™ IF573 DEVELOPMENT BOARDS

### 5.1 Sona™ IF573 Series M.2 Variant Development Board

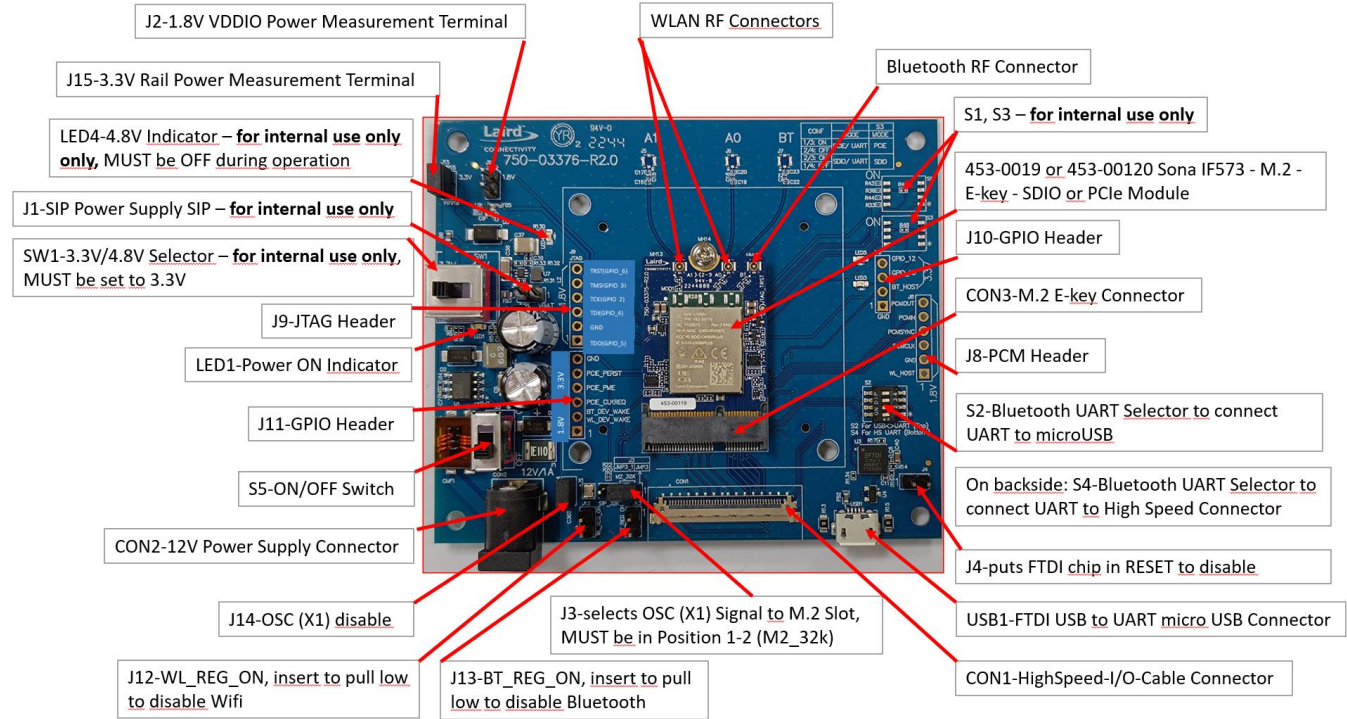

Figure 3: 940-00237 - PCBA, Sona™ IF573 Series, M.2, Key E Variant

Table 5: M.2 Development Board User Interfaces

Item	Position	Comments
3.3V Rail Power Measurement Terminal	J15	Use a suitable amp meter across J15 to measure overall power consumption of module.
1.8V VDDIO Power Measurement Terminal	J2	Use a suitable amp meter across J2 to measure VDDIO power consumption of module.
3.3V Power Supply for SIP – for internal use only	J1	Used to transfer power to SIP. Currently not supported as no SIP version available. Do not use.
4.8V Indicator– for internal use only	LED4	Lights green when 4.8V are present. Not supported as no SIP version of the DVK is available. This LED needs to be OFF during operation.
3.3V/4.8V Selector– for internal use only	SW1	Selects 4.8V to be supplied to SIP. Not supported, as no SIP version of the DVK is available. MUST be set to 3.3V.
OSC signal direction	J3	Selects OSC (X1) Signal to M.2 Slot (SUSCLK32K), needs to be in Position 1-2 (M2_32k).
JTAG Header	J9	Header to JTAG pins of module. These pins are used as GPIOs since the JTAG bus is disabled on the M.2 board.
Power ON Indicator	LED1	Lights blue when power is supplied to DVK and DVK is switched on.
GPIO Header	J11	Header to various GPIO signals. See schematics.
WL_REG_ON	J12	Used to power up the WLAN section. When this signal is high, the internal regulators are enabled and WLAN is out of reset. When this pin is low the WLAN

Item	Position	Comments
		section is in reset. It has an internal 200K pull-down resistor. Recommended to control this signal via host GPIO for optimal power control.
BT_REG_ON	J13	Used to power up the Bluetooth section. When this signal is high, the internal regulators are enabled and Bluetooth is out of reset. When this pin is low the Bluetooth section is in reset. It has an internal 200K pull-down resistor. Recommended to control this signal via host GPIO for optimal power control.
OSC (X1) Disable	J14	Remove to disable on DVK oscillator.
ON/OFF Switch	S5	Power DVK on/off.
12V Power Supply Connector	CON2	Barrel connector for 12V power supply.
WLAN RF Connectors	A0, A1	On M.2 module
Bluetooth RF Connectors	BT	On M.2 module
Sona IF573 - M.2 - E-key - SDIO or PCIe Module		Sona IF573 SDIO (P/N 453-0019) or PCIe (453-0020) Module.
M.2 E-key Connector	CON3	Populate with either Sona IF573 SDIO (P/N 453-0019) or PCIe (453-0020) Module.
HighSpeed-I/O-Cable Connector	CON1	Connect either of available daughter boards. See below for descriptions.
GPIO Header	J10	Header to various GPIO signals. See schematics.
PCM Header	J8	Header to PCM signals.
Bluetooth UART Selector to connect UART to microUSB	S2	Set all S2 sub-switches to “on” position and all S4 sub-switches to “off” to direct BT UART to Micro USB connector USB1.
Bluetooth UART Selector to connect UART to High Speed Connector	S4	Set all S4 sub-switches to “on” position and all S2 sub-switches to “off” to direct BT UART to High-Speed connector CON1.
puts FTDI chip in RESET to disable	J4	Use to disable FTDI UART/USB bridge.
FTDI USB to UART micro USB Connector	USB1	Use Micro USB cable to connect BT UART to a host.

## 5.2 Sona™ IF573 Development Board Schematics

### 5.2.1 Sona™ IF573 Development Board - Block Diagram

Below is a block diagram which illustrates circuitry of the development kit board.

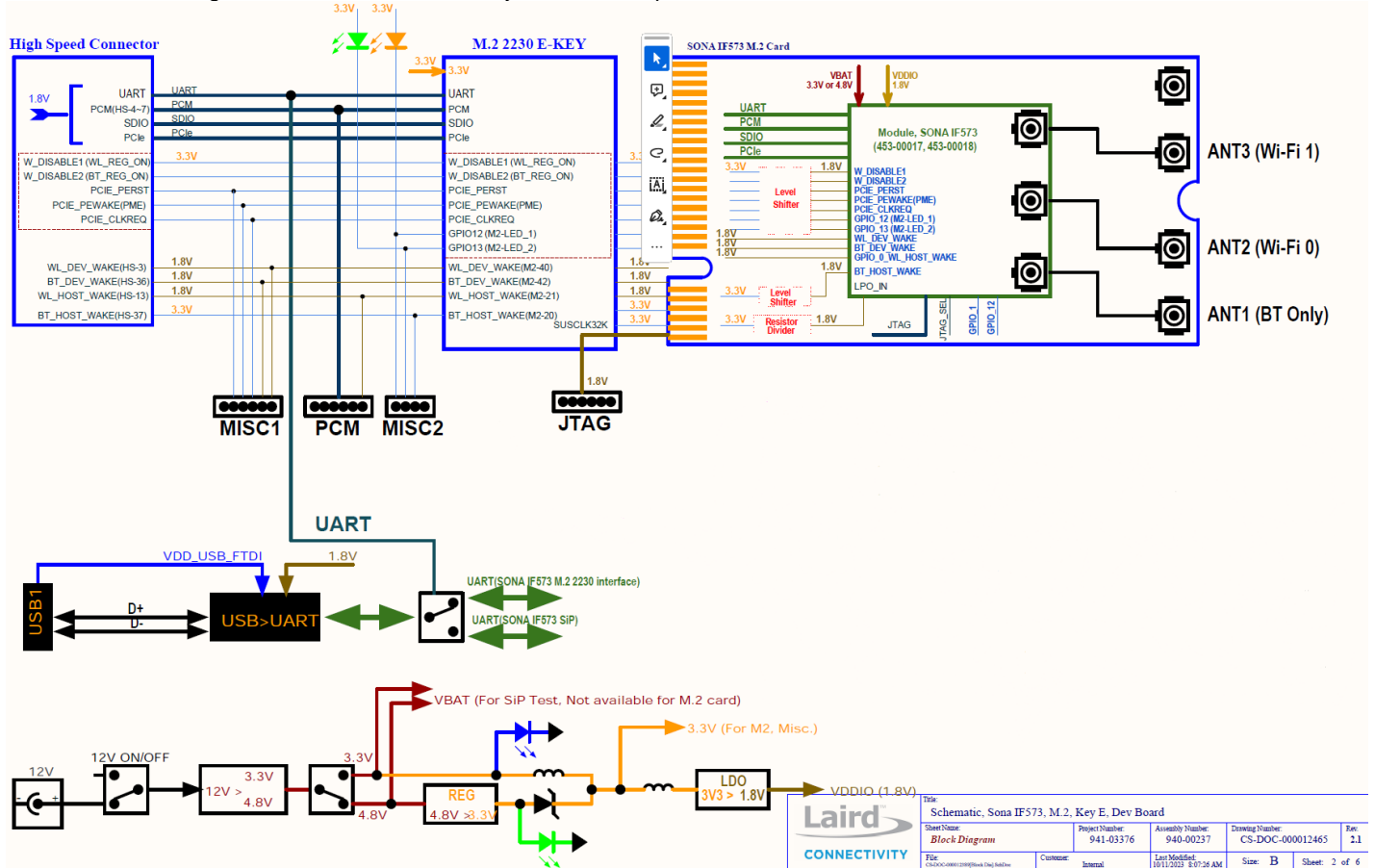

Figure 4: Sona™ IF573 Development Board Block Diagram

## 5.2.2 Sona™ IF573 Development Board - Power Schematic

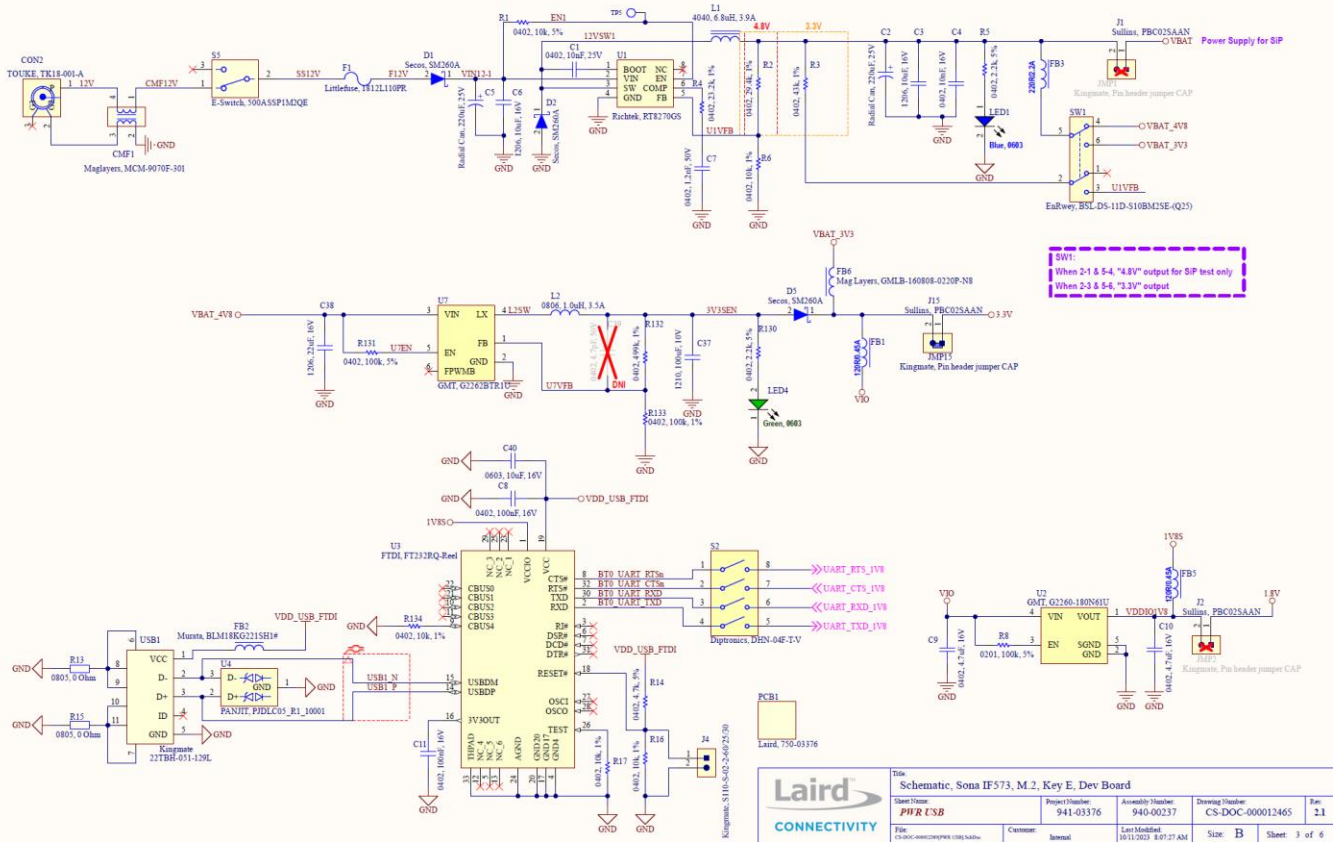

Figure 5: Power and USB to UART Schematic

Table 6: Key Components of Power and USB to UART Schematic

Component	Description
CON2	CON2-12V Power Supply Connector
S5	S5-ON/OFF Switch
J1	J1-3.3V Power Supply for SIP - <b>for internal use only. Do not use.</b>
SW1	3.3V/4.8V Selector– <b>for internal use only. Must be set to 3.3V.</b>
J2	1.8V VDDIO Power Measurement Terminal
USB1	FTDI USB to UART Micro USB Connector
S2	S2-Bluetooth UART Selector to connect UART to Micro USB
J4	Puts FTDI chip in RESET to disable
U1	Richtek RT8270GS Switching Voltage Regulator 2A, 22V, 1.2MHz Step-Down Converter
U2	GMT G2260-180N61U Low Drop-out Regulator
U3	FTDI, FT232RQ USB-to-Virtual COM port IC. Driver support is provided in the Linux kernel. Default COM settings: 115200,N,8,N. Drivers can also be downloaded from <a href="http://www.ftdichip.com/Drivers/VCP.htm">http://www.ftdichip.com/Drivers/VCP.htm</a>
U7	GMT G2262-BTR1U DC/DC Step-down Converter

### 5.2.3 Sona™ IF573 Development Board - Peripheral Schematic

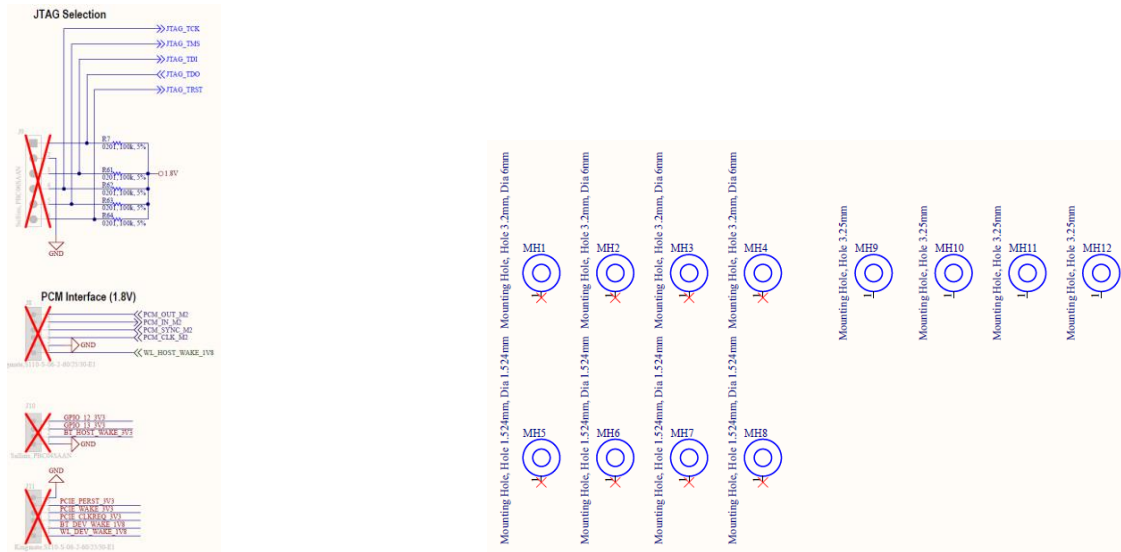

Figure 6: Sona™ IF573 Development Board M.2 Peripheral Schematic

Table 7: Key Components of Peripheral Schematic

Component	Description
J8	PCM Header
J9	JTAG Header (currently not supported)
J10	GPIO Header
J11	GPIO Header
MH1 - MH4	Mounting Hole, Hole 3.2mm, Dia 6mm
MH5 - MH8	Mounting Hole, Hole 1.524mm, Dia 1.524mm
MH9 - MH12	Mounting Hole, Hole 3.25mm

### 5.2.4 Sona™ IF573 Development Board Connector Schematic

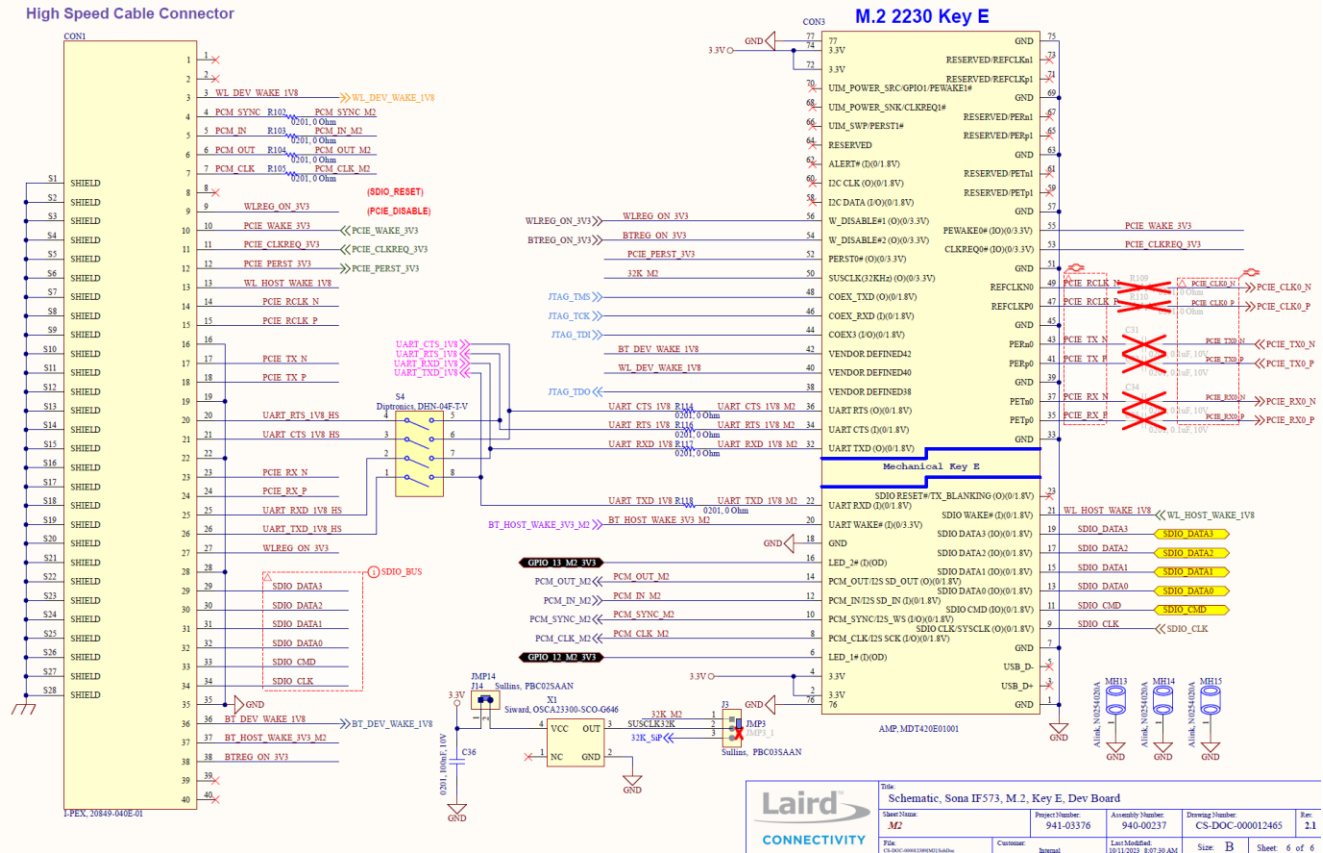

Figure 7: Sona™ IF573 Development Board – Connectors

**Note:** All six PCIe signals on M.2 Connector CON3 are connected to High-Speed Connector CON1.

Table 8: Key Components of Board Connectors Schematic

Component	Description
CON1	High speed cable connector. Connects development board with mini PCIe, M.2 PCIe, SD and micro SD daughter boards with included high speed cable. Provides multiple communication interfaces to host platform using a common development board.
CON3	M.2 Key-E connector for 453-00119 and 453-0082 Laird M.2 Modules. Not Populated on SIP variant development board.
S4	Bluetooth UART Selector to connect UART to High-Speed Connector
J3	Selects OSC (X1) Signal to M.2 Slot (SUSCLK32K), needs to be in Position 1-2 (M2_32k). <b>A customer implementation must provide a suitable 32KHz signal on pin50 (SUSCLK) of the M.2 connector.</b>
J14	JMP14, remove to disable on-board Oscillator
MH13 - MH15	Alink, N0254020A



## 6 SONA™ IF573 DAUGHTER BOARDS

### 6.1 Sona™ IF573 M.2 Daughter Board

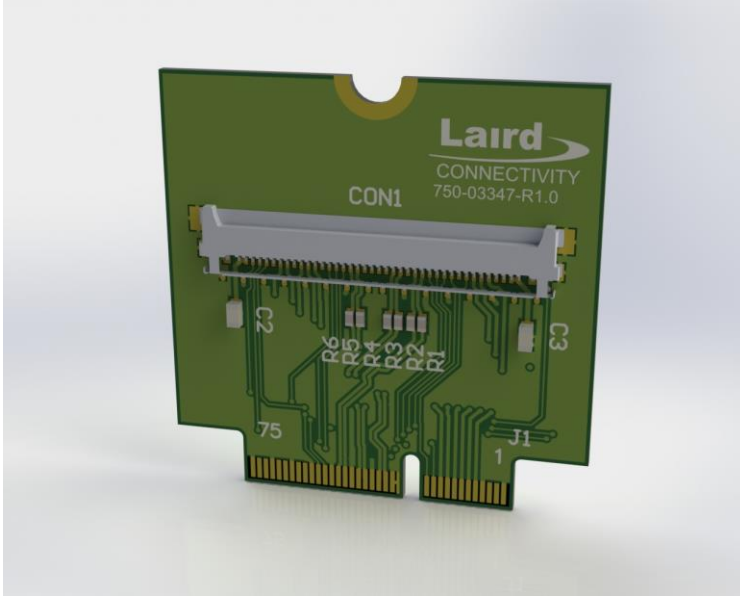

Figure 8: IF573 M.2 Daughter Board

#### 6.1.1 Sona™ IF573 M.2 Daughter Board Schematic

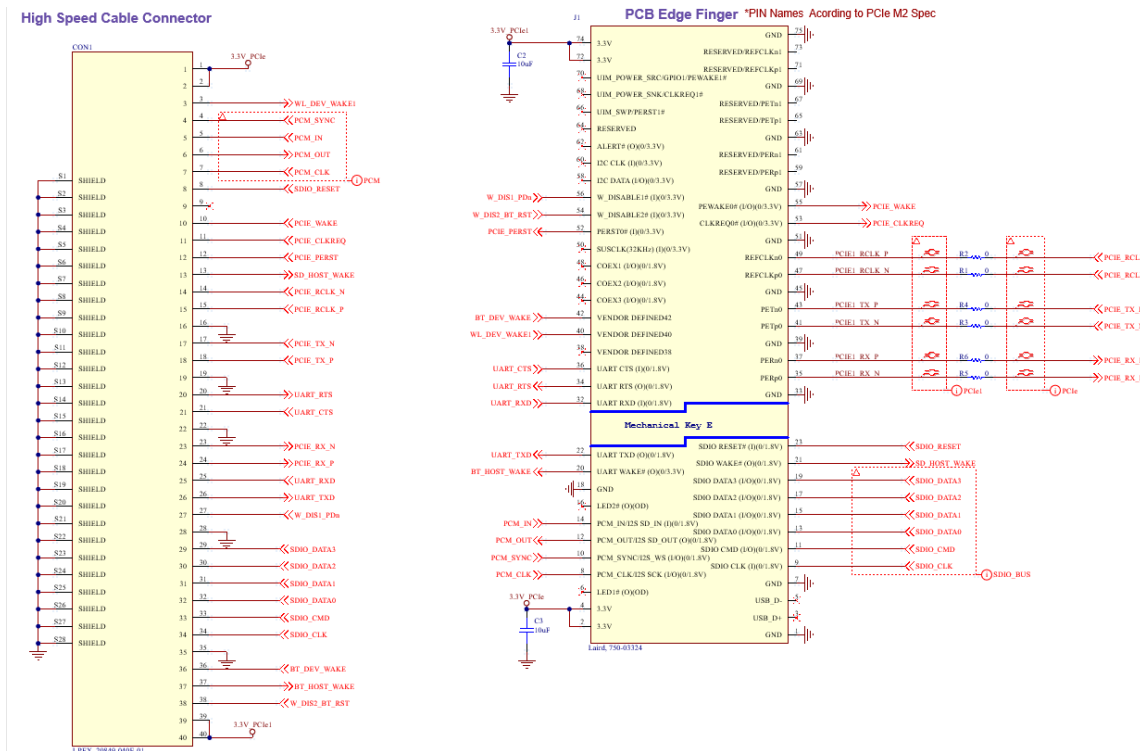

Figure 9: M.2 Daughter Board Schematic

## 6.2 Sona™ IF573 Mini PCIe Daughter Board



Figure 10: IF573 Mini PCIe Daughter Board

### 6.2.1 Sona™ IF573 mini PCIe Daughter Board Schematic

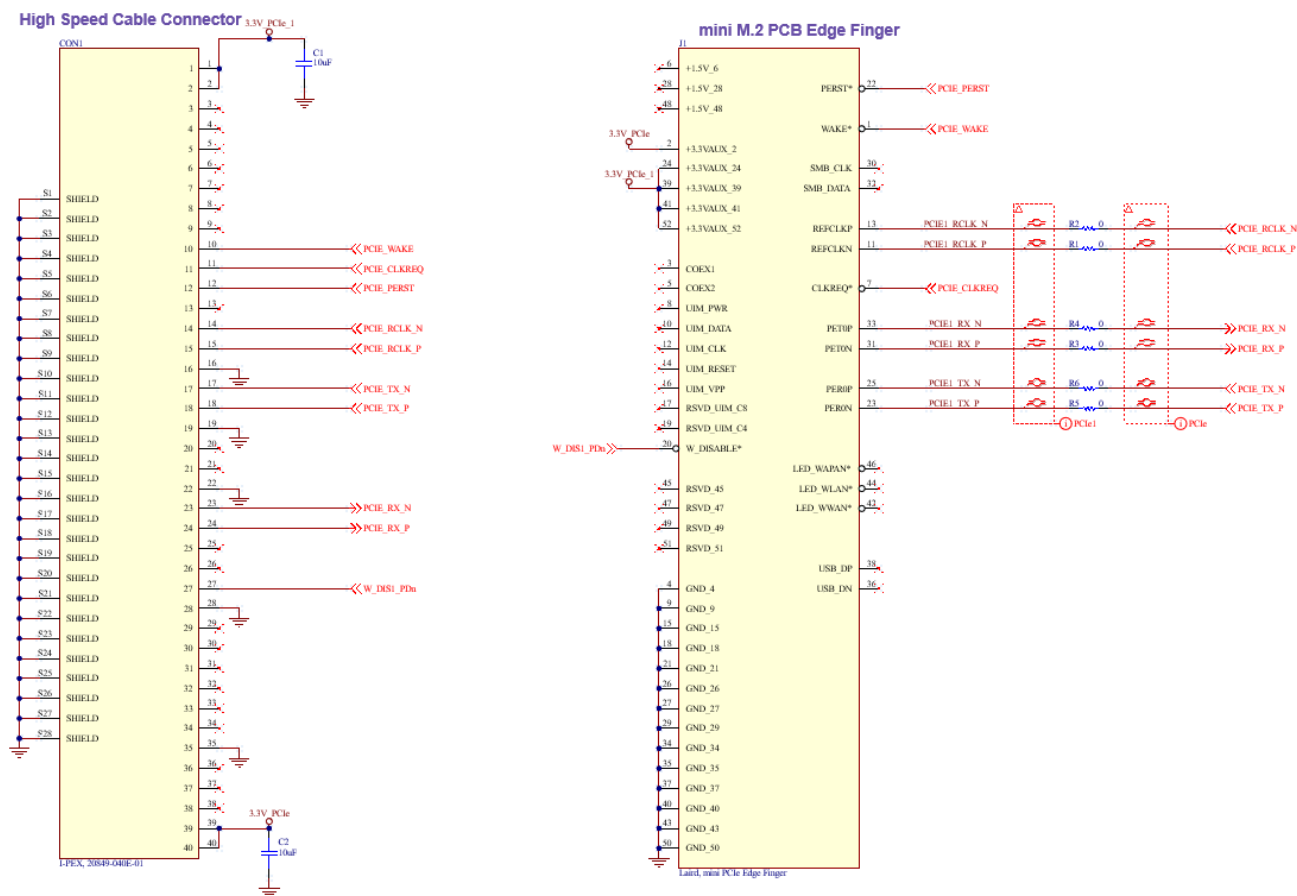

Figure 11: Mini PCIe Daughter Board Schematic



## 6.3 Sona™ IF573 SD Daughter Board

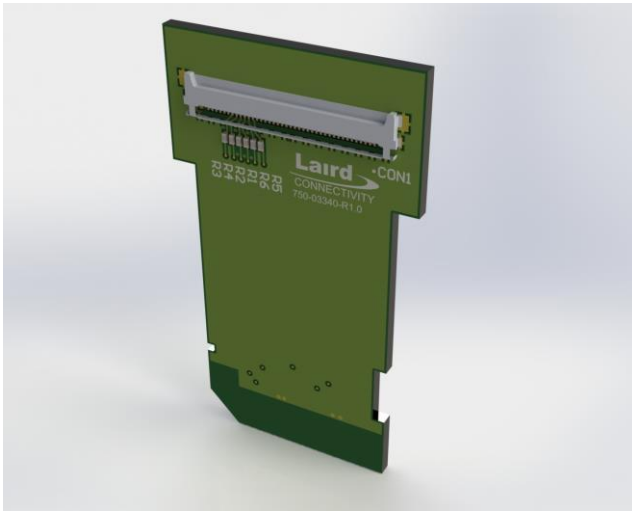

Figure 12: IF573 SD Daughter Board

### 6.3.1 Sona™ IF573 SD Daughter Board Schematic

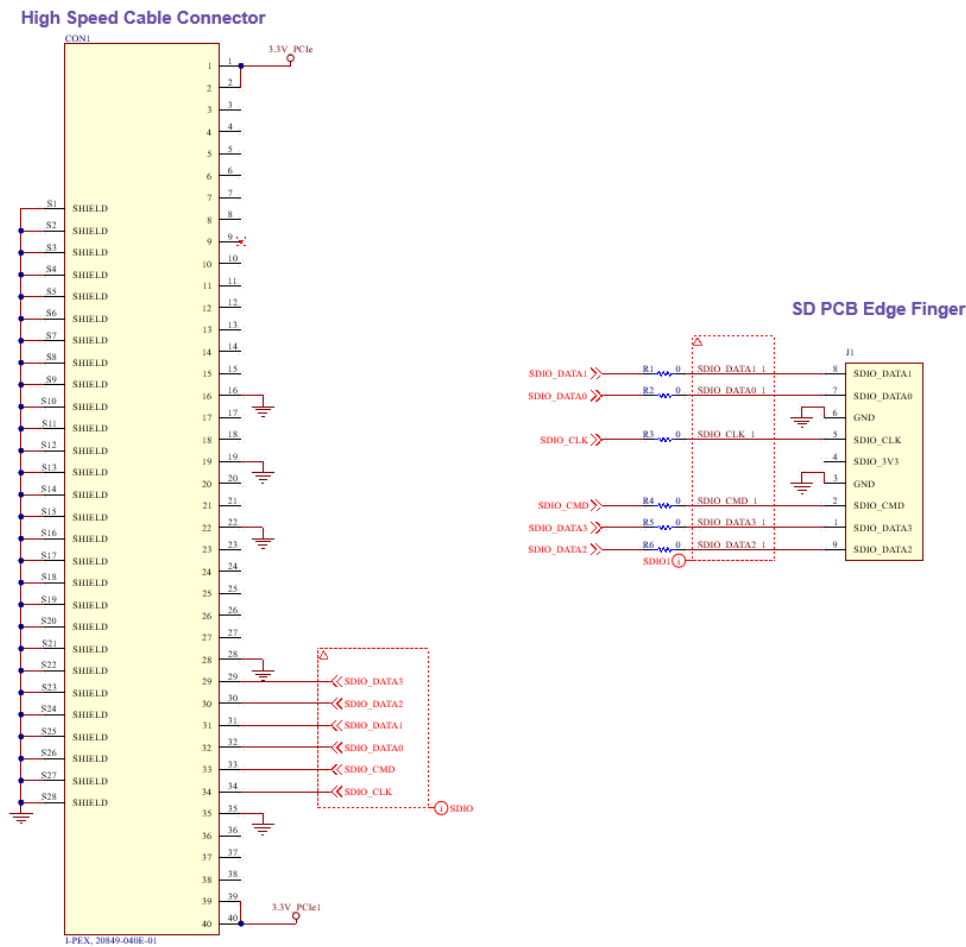

Figure 13: SD Daughter Board Schematic

## 6.4 Sona™ IF573 Micro SD Daughter Board

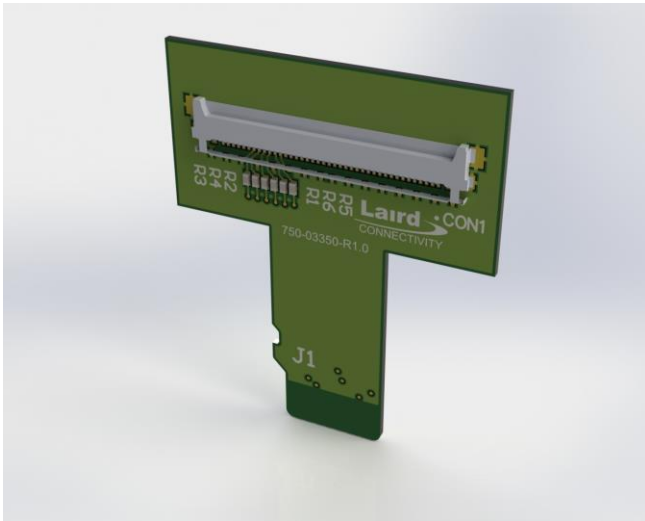
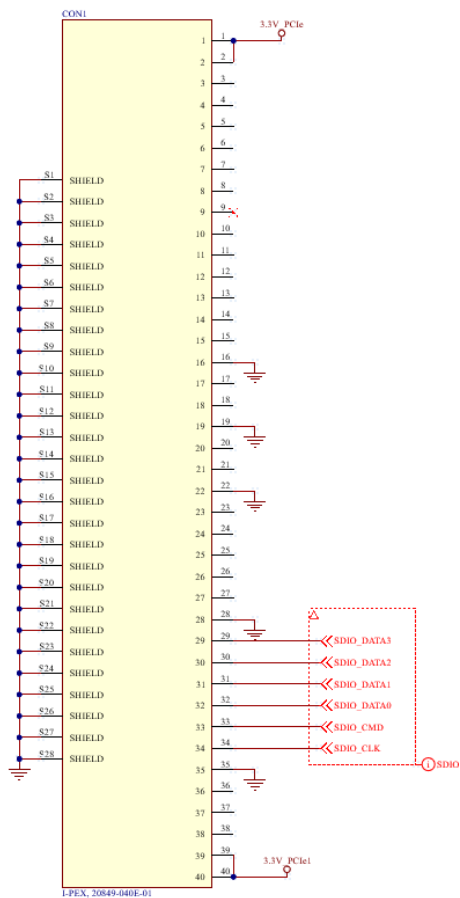

Figure 14: Sona™ IF573 Micro SD Daughter Board Schematic

### High Speed Cable Connector



### micro SD PCB Edge Finger

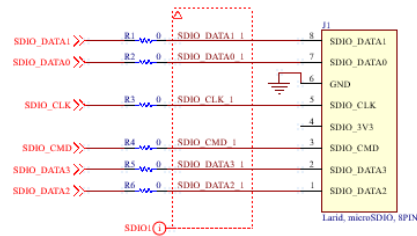

Figure 15: Micro SD Daughter Board Schematic

## 7 SONA™ IF573 DEVELOPMENT KIT ANTENNAS

### 7.1 WLAN Tri-Band 2.4/5/6 GHz Antenna

FlexMIMO 6E EFD2471A3S-10MH4L PIFA MHF4L

<https://www.lairdconnect.com/documentation/datasheet-flexmimo-6e>

This antenna connects to the A0 and A1 (WLAN) ports on the Sona™ IF573 M.2 Module onboard the DVK.

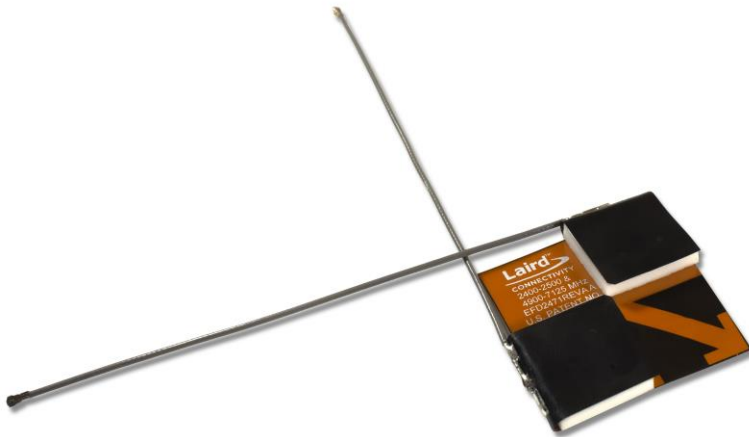

**Figure 16: WLAN Tri-Band 2.4/5/6GHz Antenna**

### 7.2 Bluetooth™ 2.4 (and 5 and 6) GHz Antenna

FlexPIFA 6E EFB2471A3S-10MH4L PIFA MHF4L

<https://www.lairdconnect.com/documentation/datasheet-flexpifa-6e>

This antenna connects to the BT (Bluetooth™) port on the Sona™ IF573 M.2 Module onboard the DVK.

This antenna serves the main purpose of being the Bluetooth antenna in this kit but actually being a Tri-Band antenna it can also be used as a single WLAN antenna.



**Figure 17: Bluetooth Antenna and WLAN Tri-Band 2.4/5/6GHz Antenna**

## 8 SONA™ IF573 DEVELOPMENT BOARD HIGH SPEED CABLE AND CONNECTORS



Figure 18: I-PEX High Speed Cable

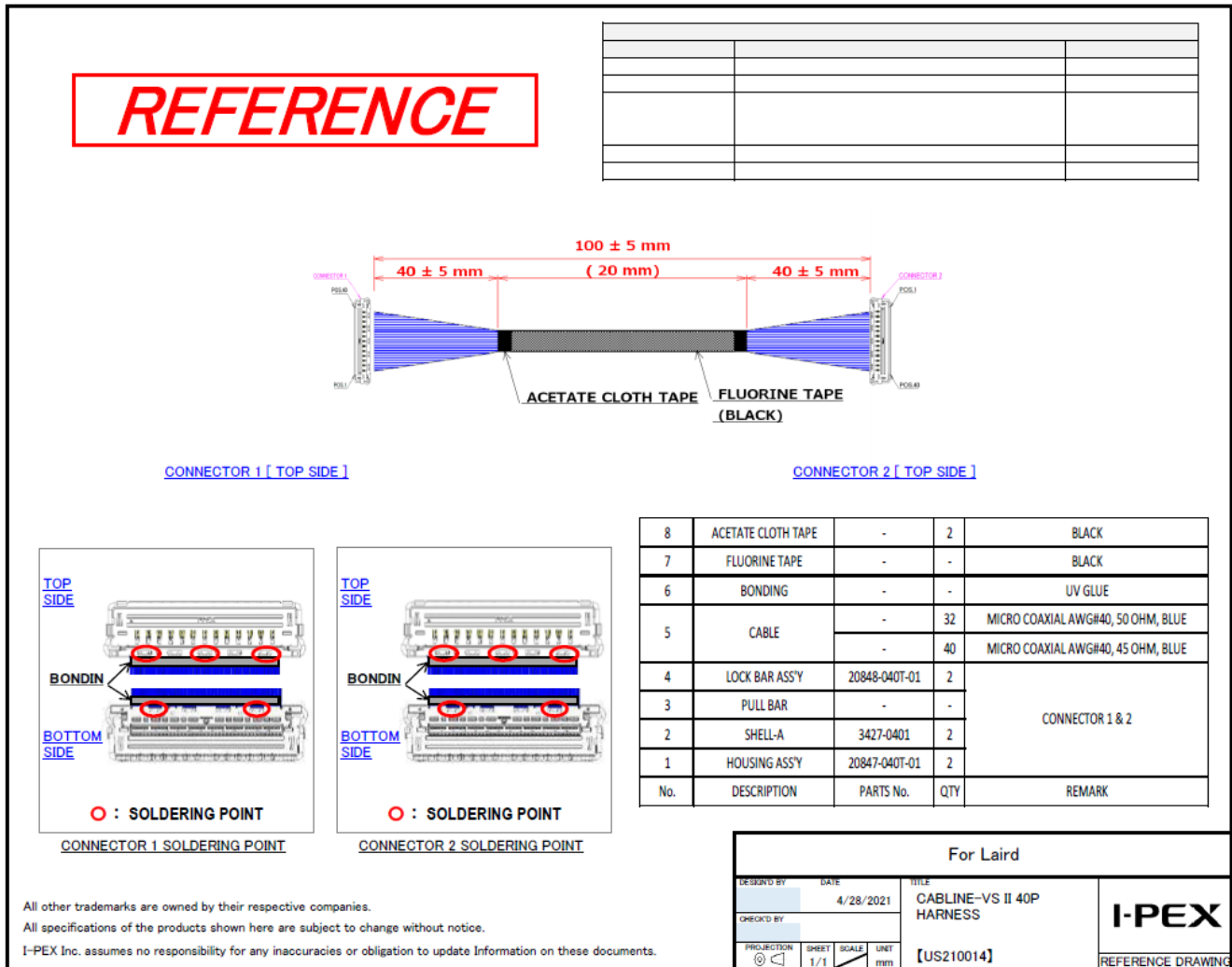

Figure 19: I-PEX High Speed Cable Drawing

## 8.1 Sona™ IF573 High Speed Cable Connector Instructions

Taken from the I-PEX CABLINE®-VS II Instruction Manual HIM-17015, found at <http://www.i-pex.com/>

**【Connector Insertion Method】**

- ① Open the lock bar ass'y. (Fig.1)

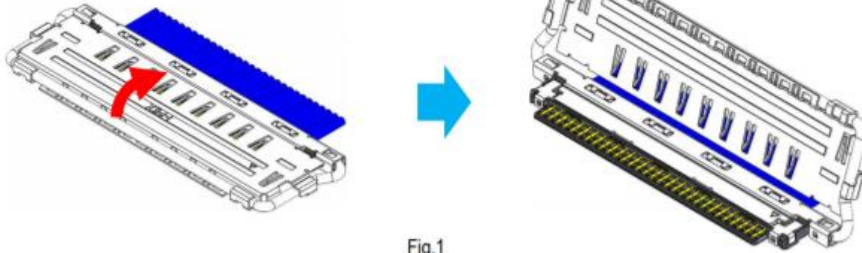

Fig.1

**<Caution 1>**

If cover is opened up more than its stopped position, cover edge may damage the cable. (Fig.2)

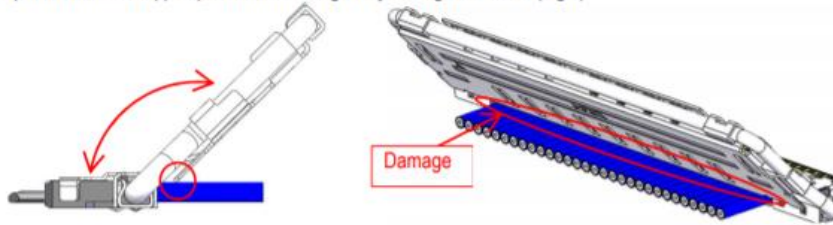

Fig.2

**Figure 20: Cable Insertion Method and Damage Warning**

- ② As shown in Fig.3, please set so that the datum pin mark of Plug connector and Receptacle connector are matched.

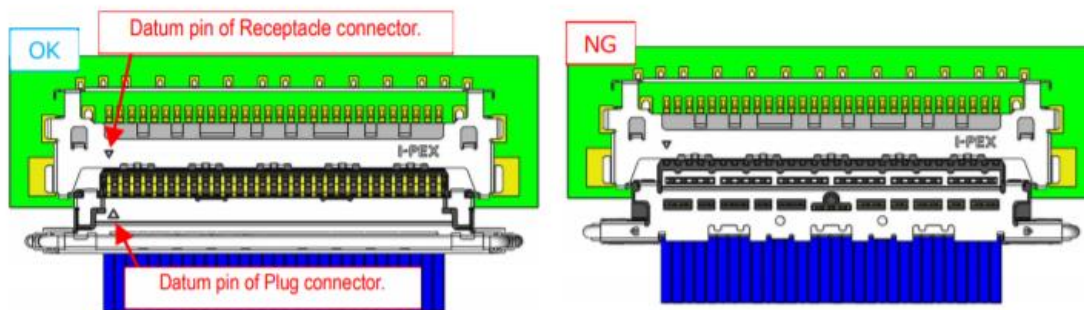

Fig.3

**Figure 21: Datum pin orientation**

- ③ Pre-insert the plug connector into the receptacle connector.  
The insertion angle in the height direction is within 8° as shown in Fig.4.  
Pre-insert until the plug connector is parallel to the receptacle connector as shown in Fig.5  
※Pre-insert without applying excessive load in the insertion direction until both sides of the plug connector overlap the receptacle connector.

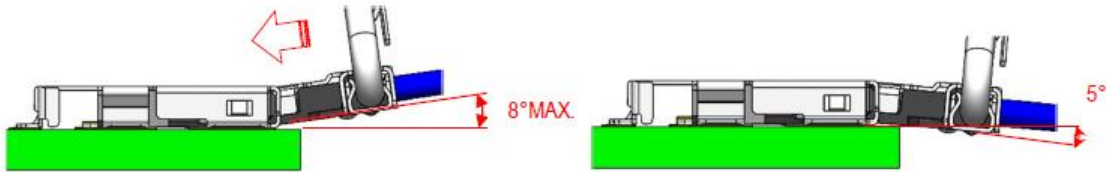

Fig.4

Pre-insert

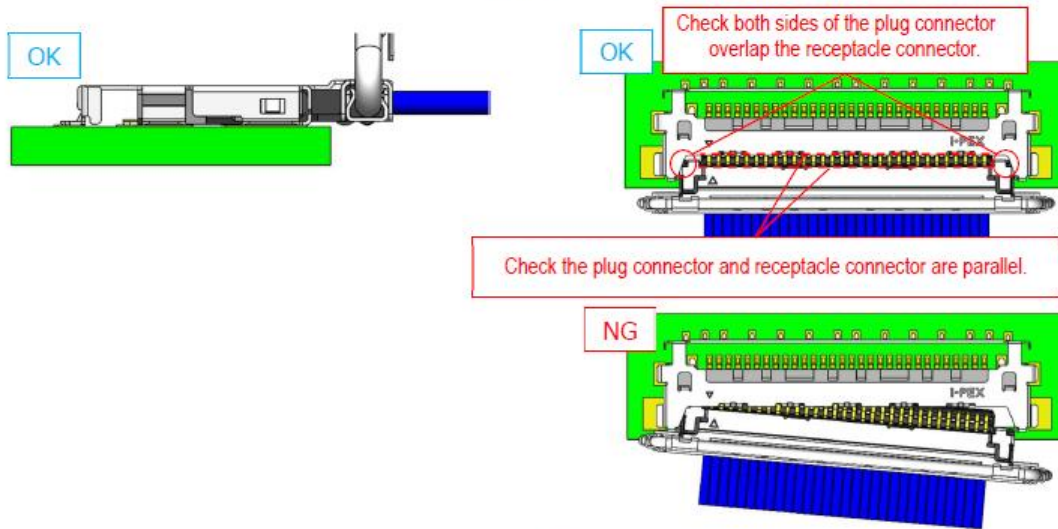

Fig.5

Figure 22: I-PEX Cable Seating Instructions



- ④ Insert the plug connector into the receptacle connector.  
Push both ends of plug connector horizontally as shown in Fig.6 and confirm there is no gap.

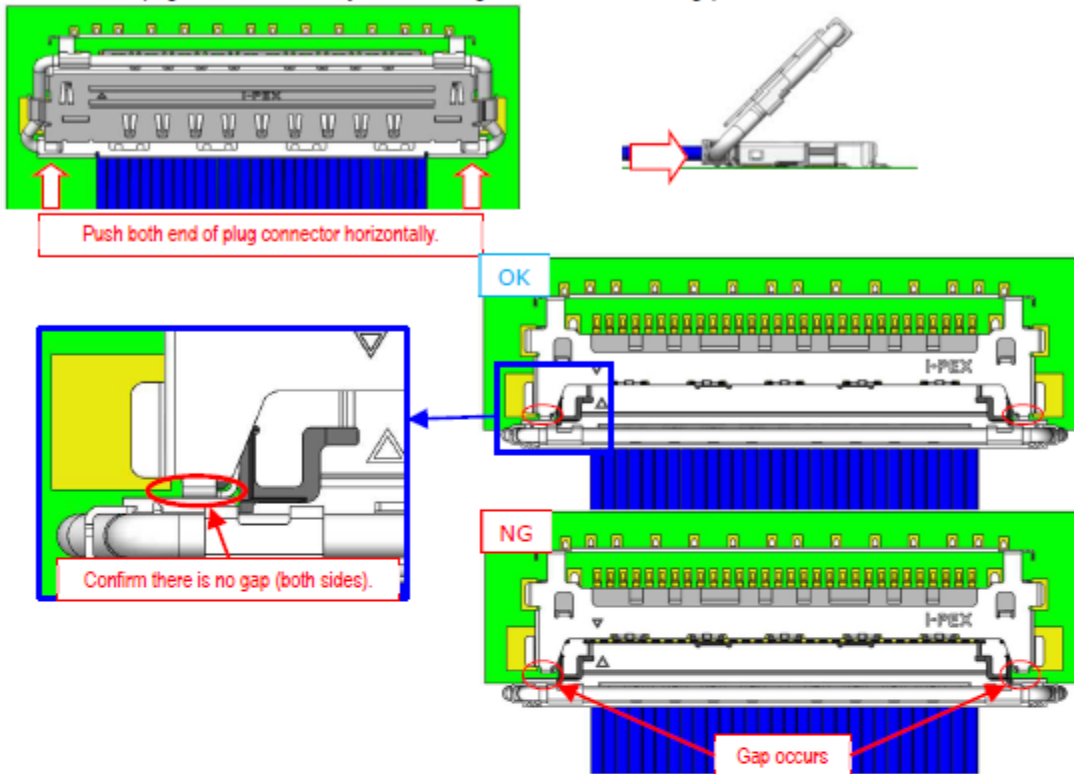

Fig.6

<Caution 3>

In inserting, please push both ends of the plug connector horizontally.  
When you push one end by one end, there is possibility to cause a gap as shown in Fig.7.

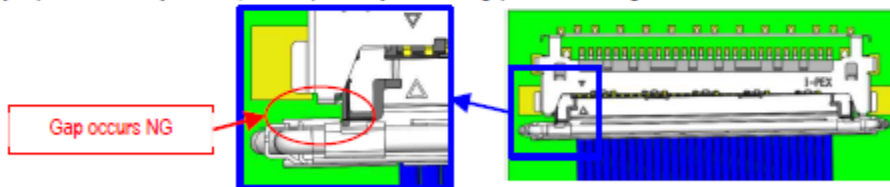

Fig.7

<Caution 4>

Don't insert the plug connector into the receptacle connector the state shown in Fig.8.  
The connector may be damaged and no conductivity.

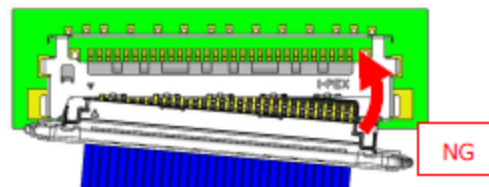

Fig.8

Figure 23: IPEX Cable Seating Instructions, Continued

- ⑤ Push two circled area of a cover down toward the PCB direction at a same time to lock receptacle shell and lock bar.

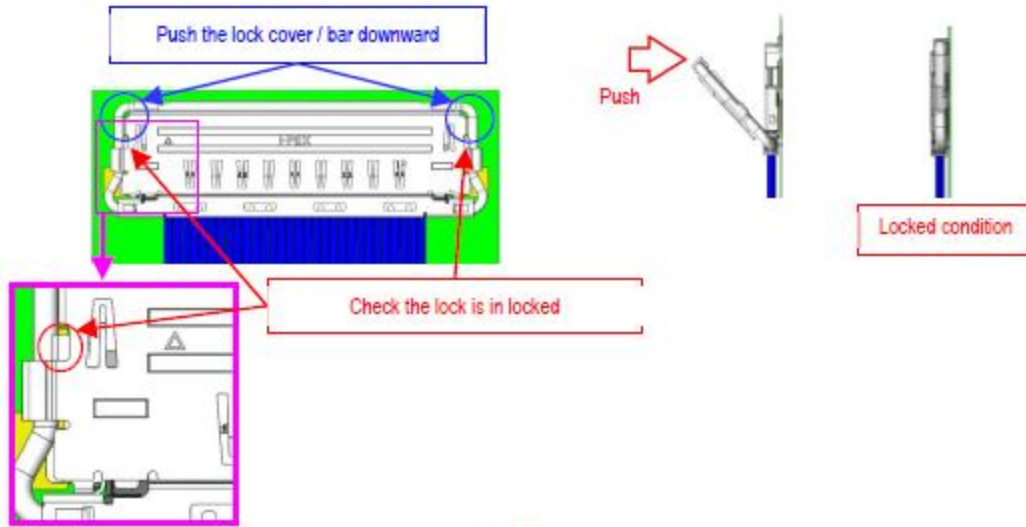

Fig.12

<Caution 7>

Do not close a cover if slant mating was confirmed. Interference of a cover and a receptacle shell may deform the connector.

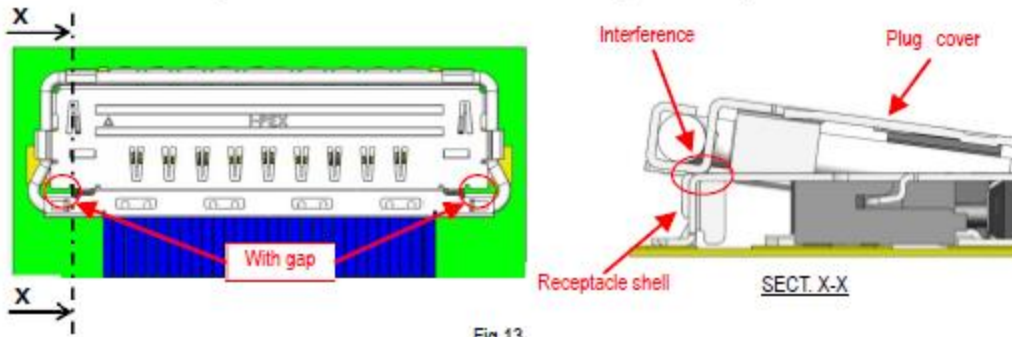

Fig.13

Figure 24: IPEX Cable Seating Instructions, Continued



## 9 ADDITIONAL INFORMATION

Please contact your local sales representative or our support team for further assistance:

<b>Headquarters</b>	Laird Connectivity 50 S. Main St. Suite 1100 Akron, OH 44308 USA
<b>Phone</b>	Americas: +1-800-492-2320 Europe: +44-1628-858-940 Hong Kong: +852-2762-4823
<b>Website</b>	<a href="http://www.lairdconnect.com/">www.lairdconnect.com/</a>
<b>Technical Support</b>	<a href="http://www.lairdconnect.com/resources/support">www.lairdconnect.com/resources/support</a>
<b>Sales Contact</b>	<a href="http://www.lairdconnect.com/contact">www.lairdconnect.com/contact</a>

---

**Note:** Information contained in this document is subject to change.

---

Laird Connectivity's products are subject to standard [Terms & Conditions](#).

[sales@lairdconnect.com](mailto:sales@lairdconnect.com)  
[support@lairdconnect.com](mailto:support@lairdconnect.com)  
[www.lairdconnect.com](http://www.lairdconnect.com)

© Copyright 2023 Laird Connectivity. All Rights Reserved. Patent pending. Any information furnished by Laird Connectivity and its agents is believed to be accurate and reliable. All specifications are subject to change without notice. Responsibility for the use and application of Laird Connectivity materials or products rests with the end user since Laird Connectivity and its agents cannot be aware of all potential uses. Laird Connectivity makes no warranties as to non-infringement nor as to the fitness, merchantability, or sustainability of any Laird Connectivity materials or products for any specific or general uses. Laird Connectivity or any of its affiliates or agents shall not be liable for incidental or consequential damages of any kind. All Laird Connectivity products are sold pursuant to the Laird Connectivity Terms and Conditions of Sale in effect from time to time, a copy of which will be furnished upon request. Nothing herein provides a license under any Laird Connectivity or any third-party intellectual property right.